



Upstream pressure sustaining valve with solenoid control Mod. XLC 325/425

The CSA Model XLC 325/425 is a globe pattern hydraulically operated automatic control valve that sustains the upstream pressure to a pre-set value regardless of variations in demand. Thanks to the solenoid control the valve will be able to close or open, in response to a signal sent from remote or by an external controller. Should the upstream pressure drop below the pilot set point the valve will close drip tight, assuring the proper operation also in static conditions.

Applications

- On the inlet supply line of storage tanks, to control the flow and the level through an electric float.
- On gravity fed supply lines to prioritize the consumers at the higher elevation zones, with the safety of opening/closing according to signals/alarms.

Accessories

- Linear position transmitter with 4-20 mA output Mod. CSA CSPL.
- On-off position transmitter Mod. CSA CSPO.
- Pressure measurement kit.
- Self-flushing and high capacity filter.

Note to the engineer

- Inlet pressure, outlet pressure, flow rate and application are required for the proper sizing and cavitation analysis.
- CSA anti-cavitation low flow stability plugs are recommended to provide an accurate regulation in case of low flow conditions.
- A minimum length of 3 DN upstream of the valve is recommended for the best accuracy.

Additional features

- XLC 325/425-FR upstream pressure sustaining with solenoid control and back-flow prevention.
- XLC 325/425-R upstream pressure relief valve with fast acting pilot and solenoid control.
- XLC 325/425-H upstream pressure sustaining valve with high sensitivity pilot and solenoid control.

Working conditions

- Fluid: treated water.
- Minimum operating pressure: 0,7 bar.
- Max. operating press.: 16 bar. Higher on request.
- Maximum temperature: 70°C.

Upstream pressure pilot adjustment range

- Blue spring: 0,7 to 7 bar.
- Red spring: 1,5 to 15 bar.
- Higher values up to 25 bar on request.
- Values lower than 0,7 available on request.

Solenoid electrical data

- Voltages: 24 V DC, 24 V/50 Hz, 230 V/50 Hz. Other voltages on request.
- Power consumption: inrush AC (VA) 24, hold AC (VA) 17 (8 W), DC hot/cold coil 8/9 W.

Operating principle

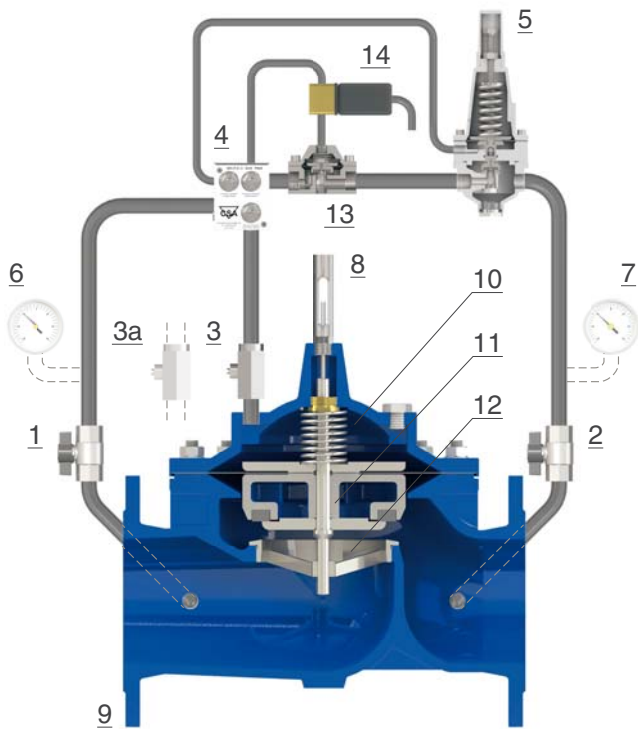

The CSA Model XLC 325/425 is an automatic control valve operated by a two ways pilot (5), sensing the line pressure through the GR.I.F.O. and a solenoid (14) acting on a flow accelerator (13). Should the upstream pressure rise above the pilot's set point the latter will open relieving the control chamber (10) and lifting up the obturator allowing flow through the main valve (9). If the line pressure drops below the pilot's set point the latter will throttle diverting pressure towards the main chamber (10), to push the obturator downwards in order to create the head loss required for pressure sustaining function. The solenoid (14) will interrupt the flow through the circuit, closing the accelerator (13), in response to signals coming from a CSA controller or from remote.

The flow in and out of the main chamber is controlled by the flow stabilizer GR.I.F.O. (4) providing accuracy and absence of chattering.

Installation layout

In the following picture the CSA XLC 325/425 is linked to a CSA controller (7) or any other electronic device sending impulses to the solenoid on the circuit. Sectioning devices (1, 2) and by-pass are needed for maintenance operations, and a filter (3) to prevent dirt. The pressure sustaining valve VSM (4) is the best choice on the by-pass thanks to its reliability also after long periods of inactivity. Anti-surge air valves FOX 3F AS (5, 6) are recommended upstream and downstream of the installation.

